

ATTENTION Weatherization Applicant
PLEASE READ CAREFULLY

To apply for Weatherization Assistance, you must submit a completed application & the required documents: If the home was previously weatherized less than 15 years from completed date, you will not be eligible.

1. Verification of Identity for all household members 18 years and older

- Acceptable proof includes a readable copy of:
 - Current Driver's License or ID card issued by State
 - ID card issued by federal, state or local government
 - Birth certificate
 - School ID card with photograph
 - ID Card for health benefits
 - Voter registration card
 - U.S. Military card/Military dependent's ID Card
 - Paycheck stubs containing the name and address of the person

2. Social Security Number Verification. Copy of Social Security Card of all household members including children. Section 205(c)(2)(C)(i) of the Social Security Act authorizes states to require Social Security Numbers as a condition of eligibility.

3. Qualified Alien Documentation

4. Income Documentation: Income of all persons residing in the dwelling unit must be documented and considered in the eligibility status.

- Social Security Benefits – copy of award Letter showing gross amount of social Security and/or SSI benefits
- Wages/Employment – copies of payroll checks showing gross amount, time period and name of person
 - Weekly – requires four (4) most recent pay stubs
 - Bi-Weekly – requires at least two(2) most recent pay stubs
 - Earnings Statement – if checks stubs are unavailable, then Earnings Statement from employer with gross amounts and time period.
- Self-Employed – copy of most recent income tax return.
- Contributions- notarized statement from source of the contribution with amounts and dates
- Unemployed – copy of benefits from unemployment Office
- Zero Income – anyone in household eighteen (18) and older that has no income must send two(2) notarized letters signed and notarized from non-relative who know of your zero income status. Also a letter from DHS verifying no income.

Income verification must include the Total Gross Household Income. You must submit copies of income for everyone in the household. If a household member is disabled, provide documentation of the disability.

5. Energy Bills. Submit copies of electric and gas/propane bills for the most recent 12 months. If you do not have this information, call you energy supplies and request a 12 month statement of consumption showing the amount of usage.

The application will not be processed or approved without the required documentation.

CADC Weatherization, P.O. Box 580, Benton, AR 72018.

5 Step Process

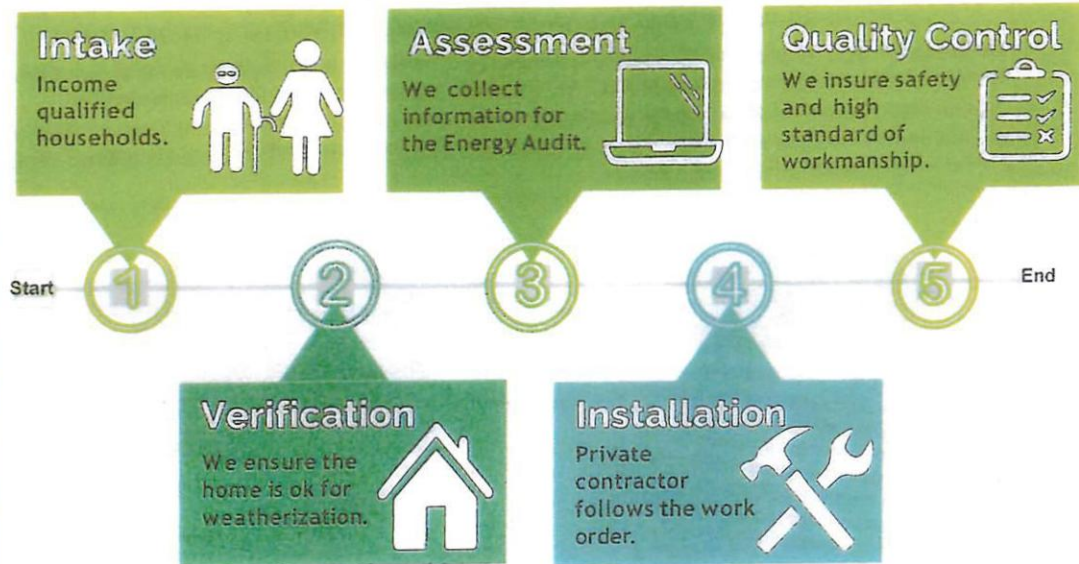

What is Weatherization?

Weatherization makes changes to an existing home so it uses less energy, feels more comfortable and is safer.

Our Goal
Lower your current energy use

Priorities
We follow 3 priorities from the Arkansas Home Weatherization Assistance Program and the U.S. Dept. of Energy

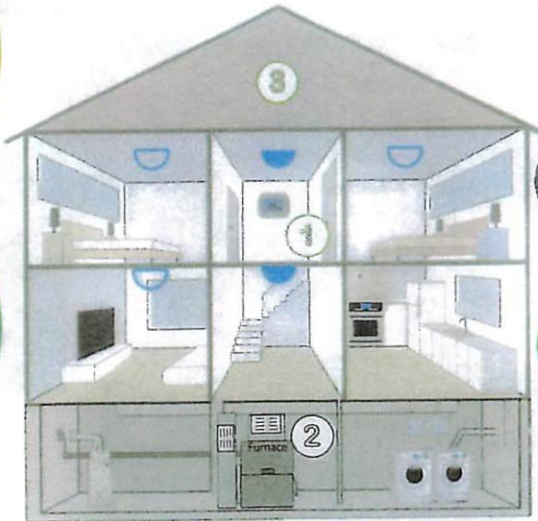

- 1** Health & Safety
 - Testing combustion appliances.
 - Gas leak detection.
 - Smoke Alarm
 - CO Detector
 - Exhaust Fan
- 2** Heating & AC
 - Test & Diagnostics Heating and cooling Systems.
- 3** Air Sealing & Insulation
 - Seal air leaks to reduce drafts.
 - Insulate attics, sidewalls, crawlspace



Ventilation Fan Agreement- ASHRAE 62.2 Waiver

We want to make your home more energy efficient and healthier.

We make homes tight (stop drafts) to save more energy. When a home is very tight we install ventilation fans to provide a continuous supply of fresh air. That fresh air will help avoid air quality problems.

We use the ASHRAE 62.2 standard to decide if your home needs a ventilation fan that runs continuously. If your home does need a ventilation fan, we **must** install it using the ASHRAE 62.2 standard or we **cannot** perform any weatherization work.

ASHRAE 62.2

ASHRAE 62.2 is an international standard for ventilation that was created for healthy indoor air quality. The Department of Energy requires Weatherization programs across the USA use the ASHRAE 62.2 standard. For more information about ASHRAE visit www.ashrae.org

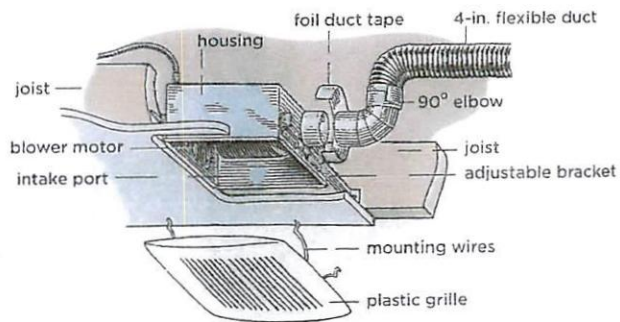

4 Important Things to Know

#1. The Auditor takes extensive notes but does NOT make decisions.



#4 The work on your house is performed by licensed and insured contractors who pass our high standards.

#3. The computer system rarely includes windows and door replacements because they are not cost effective for the amount of energy they save.

#2. The Auditor's notes are entered into a statewide computer program. It prioritizes which measures will be installed in your home.



Air Sealing with Ventilation Saves Money

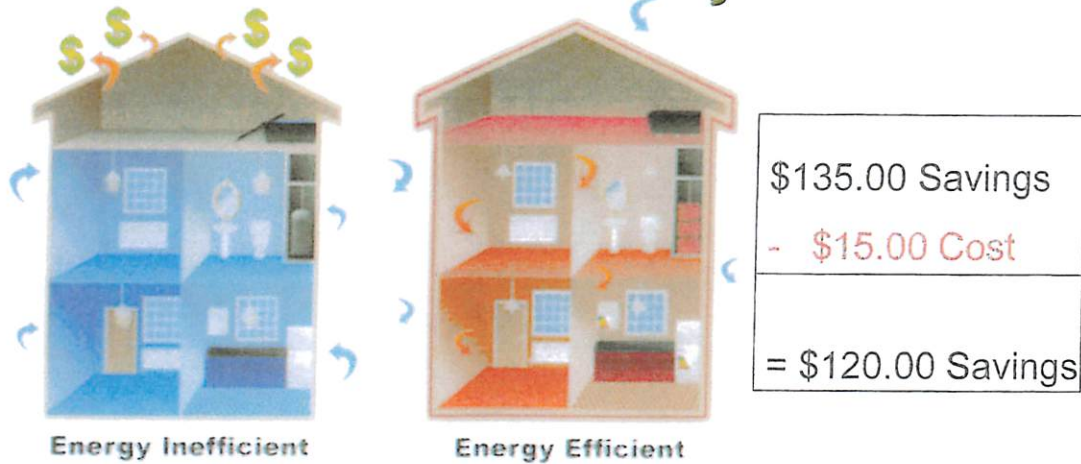

- A continuous ventilation fan in a home typically costs about \$15.00 per year.
- Making a home more tight can save \$135.00 to \$230.00 per year.
- That means you can still save money using a continuous running ventilation fan.



Indoor Air Quality Problems

This is a list of some common toxins in your home that can cause indoor air quality problems and make people sick or cause damage.

- mold
- dust mites
- volatile organic compounds (VOC)
- mildew
- bacteria
- dirt and dust particles
- pollen
- pet dander
- combustion products
- viruses
- carbon monoxide
- nitrogen dioxide

